

Zaxis120

HITACHI

Zaxis 120

Rated Engine
88 hp (65 kW)

Operating Weight
27,600 lbs (12,500 kg)

Bucket Capacity
0.34 - 1.06 yd³ (0.26 - .81 m³)



HITACHI SMARTER and FASTER

Smarter, faster, more productive yet more efficient—the versatile Hitachi Zaxis 120 can be found at construction sites all over the world. Boasting a cleaner yet more powerful engine and a host of new items as well as significant refinements, Zaxis is the next generation in excavator development.

Rigid Undercarriage

The overall rigidity of the entire undercarriage has been strengthened for increased durability.

Machine Information Center

The Machine Information Center captures and stores vital machine performance data such as engine speeds, hydraulic temperatures, pump pressures, alarms and faults, hours of operation, and more. The data is downloadable through an mSeries Palm™ Pilot and is transferred to your PC. Special PC software interprets the data and generates valuable machine performance reports and graphs highlighting machine utilization, performance history, and more to help users improve productivity and profit.

Multi-function Operations

The Zaxis 120 continues the Hitachi tradition of smooth, multi-functioning excavators. Executing combined operations such as simultaneous swinging and traveling are easy with Zaxis.

High-Power Engine

The Isuzu CC-4BG1TC generates

- 84 hp @ 1,950 rpm in P mode (62 kW/min⁻¹)
- 88 hp @ 2,150 rpm in H/P mode (65 kW/min⁻¹)
- 253 lbf•ft max. torque @ 1,600 rpm (35 kgf•m/min⁻¹)

and meets all Tier II emissions regulations.

Durable

Extensive steps have been taken to improve basic performance and overall durability.

Safety, Comfort, and Convenience

The operator's compartment is designed for both comfort and operating efficiency.



Higher Productivity

Zaxis uses the latest technologies to achieve lower total operational costs while boosting productivity. The large Isuzu intercooler-equipped engine provides an excellent balance of power and fuel efficiency.

Cab Comfort

The easy-to-read monitor panel and switches are located near the operator to minimize fatigue and enhance operator control. Noise levels inside the cabin have been reduced. The Auto-control air conditioner allows you to set a specific temperature, then forget it. Bi-level air ducts are positioned throughout the cab to promote even air flow.



Lower Operating Costs

Reduced fuel consumption, a strengthened main frame, front attachment, and undercarriage, longer lubrication intervals, 4,000-hour hydraulic oil and 1,000-hour hydraulic oil filters all work together to extend the durability of Zaxis while reducing running and repair costs.

Work Modes

Two modes simplify excavating operations. Select the "Digging" mode for smooth and speedy front operations or "Attachment" to use a wide variety of tools such as breakers, compactors, and crushers.

The powerful engine and hydraulic system work together to bring the maximum amount of excavating forces to the toughest of job sites.



Cab Safety

The CRES (Center pillar Reinforced Structure) rigid cab is designed with safety in mind. The closed-section pillar and reinforcing members at central areas withstand vertical and horizontal external forces. This can help reduce the potential of operator injury in the event of an accident.

Operator Command

The newly refined hydraulic system gives the operator unprecedented control. The bucket regenerative system makes light-duty operation quicker.

Increased Travel and Swing Power

Armed with plenty of dependable power for travel and swing operations, the Zaxis 120 is ready for the toughest of terrains and job sites thanks to improved travel motors and swing reduction gear. It has 9% more swing torque and 4% more travel power than the EX120.

Auto Acceleration and Auto Idle

Engine speed is automatically controlled in response to the amount of lever operation. This helps reduce fuel consumption, especially during light-load work. The Auto-idle control reduces the engine speed automatically to save energy when the lever is in neutral.



Easy-to-read monitor panel.



A low-noise muffler and the Isuzu Tier 2 emissions control engine ensure a quieter, more environmentally friendly excavator. Plastic parts are labeled for easy recycling. Wiring is lead-free.

Cab design both guards the operator and contributes to efficient operation through its comfortable, ergonomic layout and its CRES design.



ENGINE

ModelIsuzu CC-4BG1TC
 Type4-cycle water-cooled, direct injection
 AspirationTurbocharged, intercooled
 No. of cylinders4
 Rated power SAE J1349, net
 H/P mode88 hp (65 kW) @ 2,150 rpm (min⁻¹)
 P mode84 hp (62 kW) @ 1,950 rpm (min⁻¹)
 Maximum torque253 lbf•ft (35 kgf•m) @ 1,600 rpm (min⁻¹)
 Piston displacement264 in³ (4,329 L)
 Bore and stroke4.13" x 4.92" (105 mm x 125 mm)
 Batteries2 x 12 V, 55 AH
 GovernorMechanical speed control with stepping motor

HYDRAULIC SYSTEM

Work mode selector allows operator to choose between Digging mode or Attachment mode.
 Engine speed sensing system.
 Main pumps2 variable displacement axial piston pumps
 Max. oil flow2 x 27.7 US gpm (2 x 105 L/min, 2 x 23.1 Imp gpm)
 Pilot pump1 gear pump
 Max. oil flow8.7 US gpm (33 L/min, 7.3 Imp gpm)

Hydraulic Motors

Travel2 variable displacement axial piston motors
 Swing1 axial piston motor

Relief Valve Settings

Implement circuit4,980 psi (350 kgf/cm²)
 Swing circuit4,690 psi (330 kgf/cm²)
 Travel circuit4,980 psi (350 kgf/cm²)
 Pilot circuit570 psi (40 kgf/cm²)

Hydraulic Cylinders

High-strength piston rods and tubes. Cylinder cushion mechanisms provided in boom and arm cylinders to absorb shock at stroke ends.

Dimensions:

	Qty.	Bore	Rod Diameter
Boom	2	4.13" (105 mm)	2.76" (70 mm)
Arm	1	4.53" (115 mm)	3.15" (80 mm)
Bucket	1	3.94" (100 mm)	2.76" (70 mm)

Hydraulic Filters

Hydraulic circuits use high-quality hydraulic filters. A suction filter is incorporated in the suction line, and full-flow filters in the return line and swing/travel motor drain lines.

UPPERSTRUCTURE

Revolving Frame

Welded sturdy box construction, using heavy-gauge steel plates for ruggedness. D-section frame for resistance to deformation.

Swing Mechanism

Axial piston motor with planetary reduction gear is bathed in oil. Swing circle is single-row, shear-type ball bearing with induction-hardened internal gear. Internal gear and pinion gear are immersed in lubricant. Swing parking brake is spring-set/hydraulic-released disc type.

Swing speed13.7 rpm (min⁻¹)

Operator's Cab

Independent roomy cab, 40" (1 005 mm) wide by 66" (1 675 mm) high, conforming to ISO Standards. Reinforced glass windows on 4 sides for visibility. Front windows (upper and lower) are openable. Adjustable, reclining seat with armrests; movable with or without control levers.

CONTROLS

Pilot Controls

Hitachi's original shockless valve and quick warm-up system built in the pilot circuit. Hydraulic warm-up control system for engine and hydraulic oil.

Implement levers2
 Travel levers with pedals2

UNDERCARRIAGE

Tracks

Tractor-type undercarriage. Lubricated track rollers, idlers, and sprockets with floating seals. Track shoes with triple grousers made of induction-hardened rolled alloy. Heat-treated connecting pins with dirt seals. Hydraulic (grease) track adjusters with shock-absorbing recoil springs.

Number of Rollers and Shoes on Each Side, standard N.A. model

Upper rollers1
 Lower rollers7
 Track shoes44

Traction Device

Each track driven by 2-speed axial piston motor through planetary reduction gear for counter-rotation of the tracks. Sprockets are replaceable. Parking brake is spring-set/hydraulic-released disc type. Travel shockless relief valve built in travel motor absorbs shocks when stopping travel.

Automatic transmission system: High-Low.

Travel speeds High:0-3.4 mph (5.5 km/h)
 Low:0-2.1 mph (3.4 km/h)

Maximum traction force22,900 lbf (10 400 kgf)
 Gradeability35° (70%) continuous

SERVICE REFILL CAPACITIES

	US gal	Liters	Imp gal
Fuel tank	66.1	250.0	55.0
Engine coolant	5.0	19.0	4.2
Engine oil	4.2	15.8	3.5
Swing mechanism (each side)	0.8	3.2	0.7
Travel final device (each side)	1.1	4.0	0.9
Hydraulic system	34.3	130.0	28.6
Hydraulic tank	18.2	69.0	15.2

WEIGHTS/GROUND PRESSURE

Standard North America backhoe model Zaxis 120:

15' 1" (4.60 m) boom, 8' 3" (2.52 m) arm and 0.78 yd³ (0.60 m³) PCSA heaped bucket, 28" (700 mm) shoes.

Weight:27,600 lb (12 500 kg)

Ground pressure:4.12 psi (0.29 kgf/cm²)

Other models include 20" (500 mm) and 24" (600 mm) and triple grouser shoes. Dozer blade is optionally available

BACKHOE ATTACHMENTS

Boom and arms are of welded, box-section design.

15' 1" (4.60 m) boom, and 8' 3" (2.52 m) and 9' 11" (3.01 m) arms are available.

DOZER BLADE (OPTION)

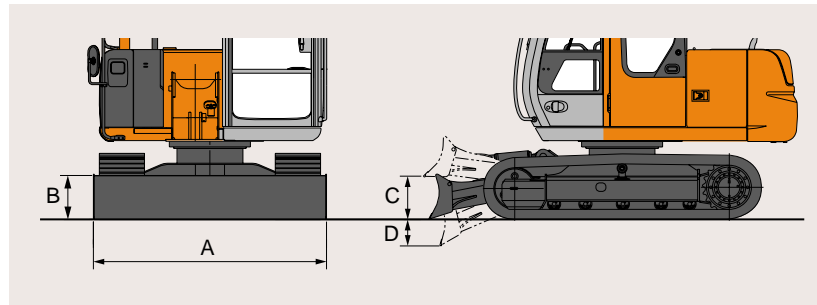

- A Overall width of blade..... 8'10" (2 690 mm)
 B Overall height of blade..... 1'7" (483 mm)
 C Max. raising height above ground.....1'11" (580 mm)
 D Max. lowering depth from ground..... 1'8" (510 mm)

EQUIPMENT

STANDARD EQUIPMENT

ENGINE

- H/P mode control
- E mode control
- 50 A alternator
- Dry-type air filter with evacuator valve (with safety element)
- Cartridge-type engine oil filter
- Cartridge-type fuel filter
- Radiator and oil cooler with dust protective net
- Radiator reserve tank
- Fan guard
- Isolation-mounted engine
- Auto-idle system
- Auto acceleration system

HYDRAULIC SYSTEM

- Work mode selector
- Engine speed sensing system
- E-P control system
- Quick warm-up system for pilot circuit
- Shockless valve in pilot circuit
- Boom-arm anti-drift valve
- Control valve with main relief valve
- Extra port for control valve
- Suction filter
- Full-flow filter
- Pilot filter

CAB

- CRES (Center pillar Reinforced Structure) cab
- All-weather sound-suppressed steel cab
- Reinforced, tinted (bronze color) glass windows
- 4 fluid-filled elastic mounts
- Upper and lower front windows and left side windows that open
- Intermittent windshield retractable wipers
- Front window washer
- Adjustable reclining seat with adjustable armrests
- Footrest
- Electric double horn

- AM-FM radio with digital clock
- Auto-idle/acceleration selector
- Seat belt
- Drink holder
- Cigar lighter
- Ashtray
- Storage box
- Glove compartment
- Floor mat
- Heater
- Pilot control shut-off lever
- Engine stop knob
- Auto control air conditioner

MONITOR SYSTEM

- Meters:
Hourmeter, trip meter, engine coolant temperature gauge, and fuel gauge
- Warning lamps:
Alternator charge, engine oil pressure, engine overheat, air filter restriction, and minimum fuel level
- Pilot lamps:
Engine preheat, work light, auto-idle, auto-acceleration, digging mode, attachment mode
- Alarm buzzers:
Engine oil pressure and engine overheat

LIGHTS

- 2 working lights

UPPERSTRUCTURE

- Undercover
- 5,400 lb (2 450 kg) counterweight
- Fuel level float
- Hydraulic oil level gauge
- Tool box
- Utility space
- Rearview mirror (right & left side)
- Swing parking brake

UNDERCARRIAGE

- Travel parking brake
- Travel motor covers
- Track guards and hydraulic track adjuster
- Bolt-on sprocket
- Upper rollers and lower rollers
- Reinforced track links with pin seals
- 28" (700 mm) triple grouser shoes
- Travel motion alarm device

FRONT ATTACHMENTS

- HN bushing
- WC thermal spraying
- Reinforced resin thrust plate
- Flanged pin
- Bucket clearance adjust mechanism
- Monolithically cast bucket link A
- Centralized lubrication system
- Dirt seal on all bucket pins

MISCELLANEOUS

- Lockable machine covers
- Lockable fuel filling cap
- Skid-resistant tapes, plates and handrails.
- Travel direction mark on track frame
- Onboard MIC

OPTIONAL EQUIPMENT

- Hose rupture valves
- Tropical cover
- 20" (500 mm), 24" (600 mm) triple grouser shoes
- Dozer blade

HITACHI

Hitachi Construction Products
 P.O. Box 8806 • 1515 5th Avenue • Moline, IL 61265

www.hitachiconstruction.com

DKA120HT (02-12)

These specifications are subject to change without notice. Illustrations and photos show the standard models, and may or may not include optional equipment, accessories, and all standard equipment with some differences in color and features.